

THE FOUR POINT PAVLLION

INTERPRETATION CENTER

With increasing importance of Ahmedabad as Heritage City, Manek Burj stands with its own glory and grandeur. The 600 years old burj makes an important landmark in the city of Ahmedabad.

The take for the design is very simple by keeping in mind the fragility of the structure. Hence, the intervention just touches by four points on the ground with very light structure of steel and wooden planks as space making elements.

The design sits lightly on the mass structure of burj giving importance to the history and construction but stills owns its identity. The structure has 2 partition walls separating the chaos and serenity of the place around and focusing on the panoramic view of the river front and the market below. Roof of the building is elevated creating same sense with the sky and ground.

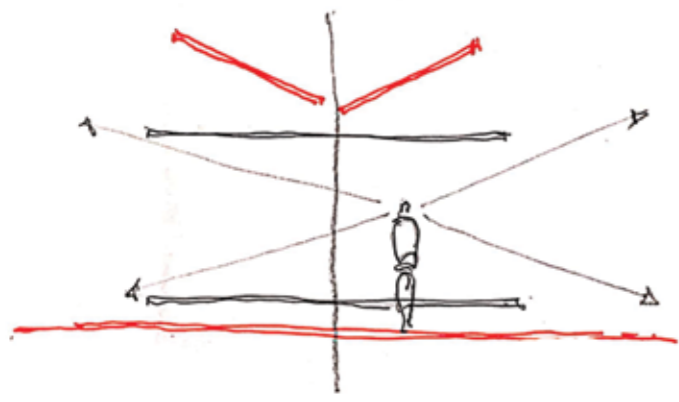
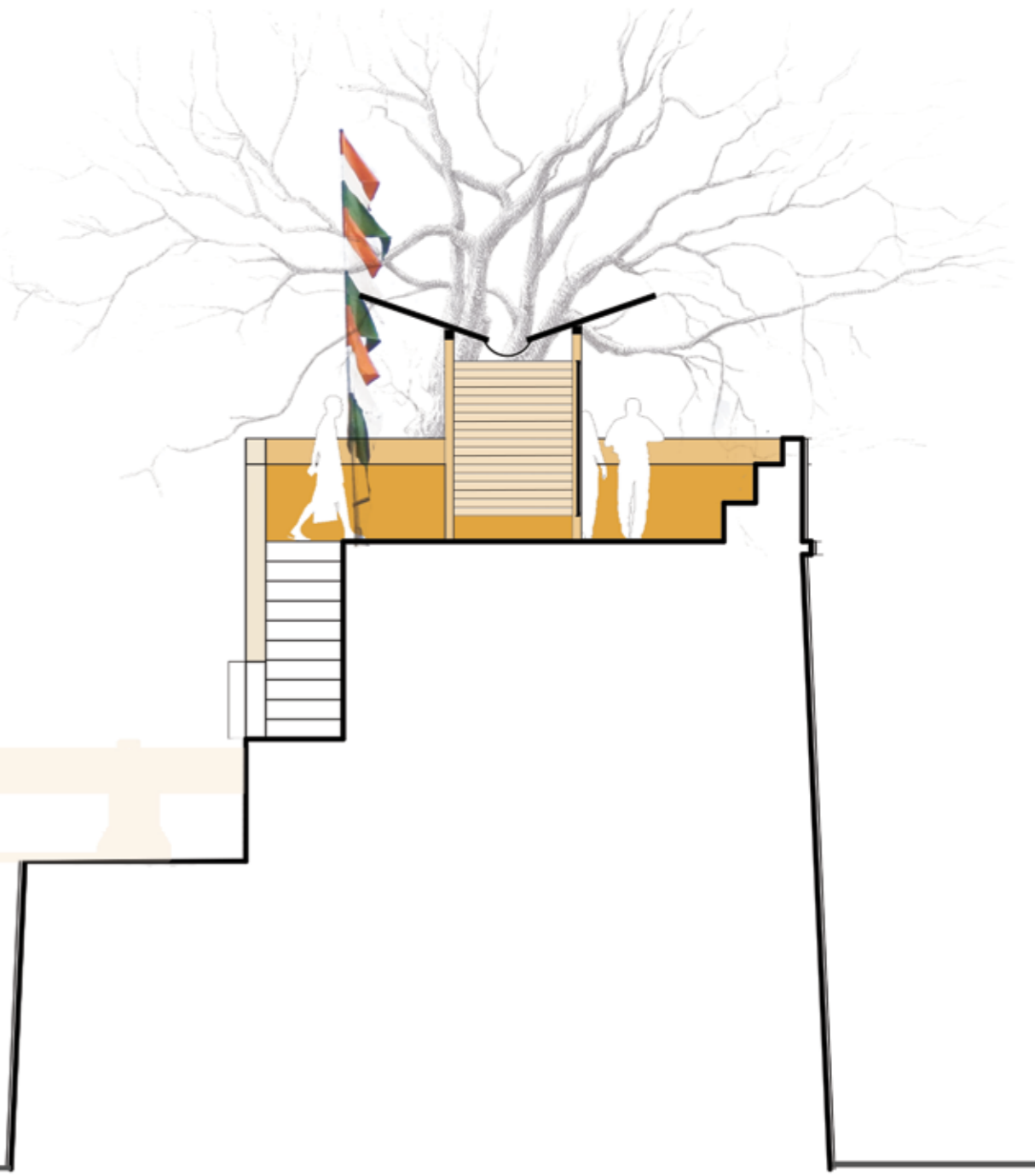
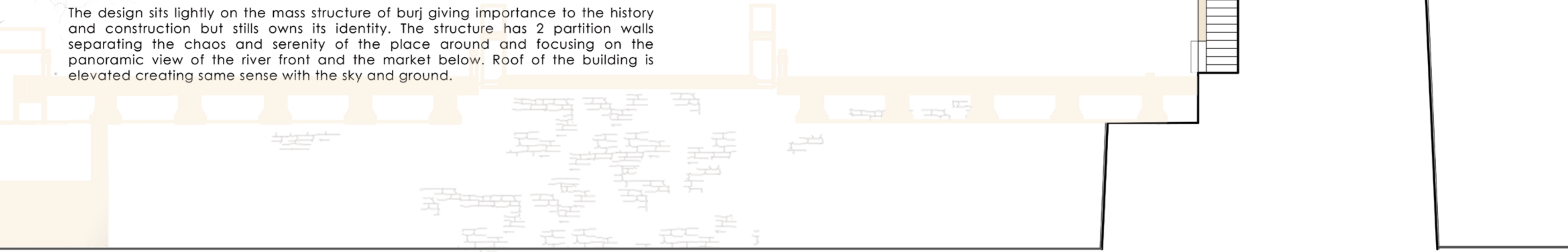

Sensitively touching ground and sky

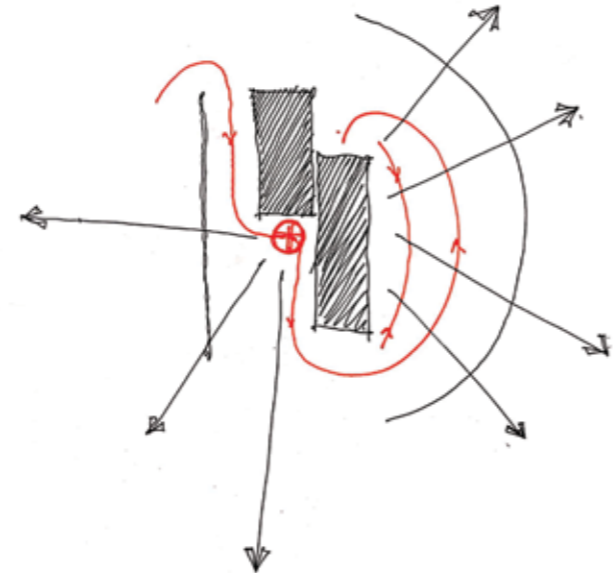

Circulation and pause

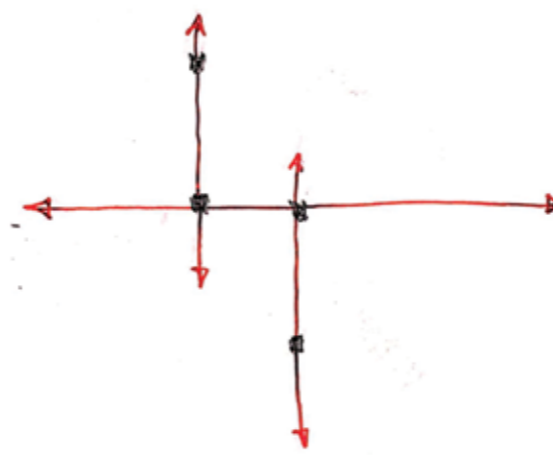

Four points for roof and wall

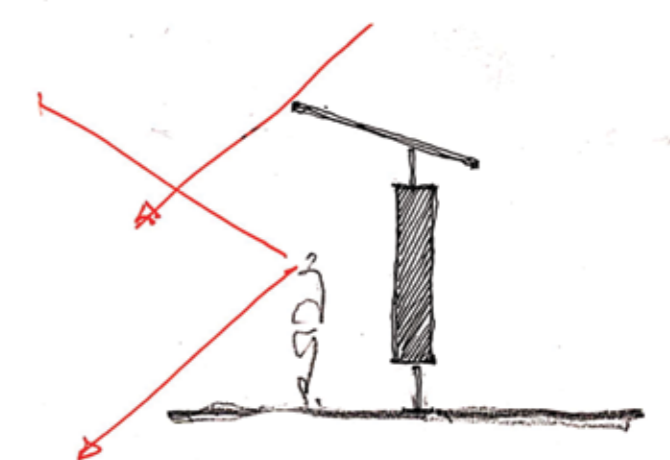

Walls as an expression of space and history

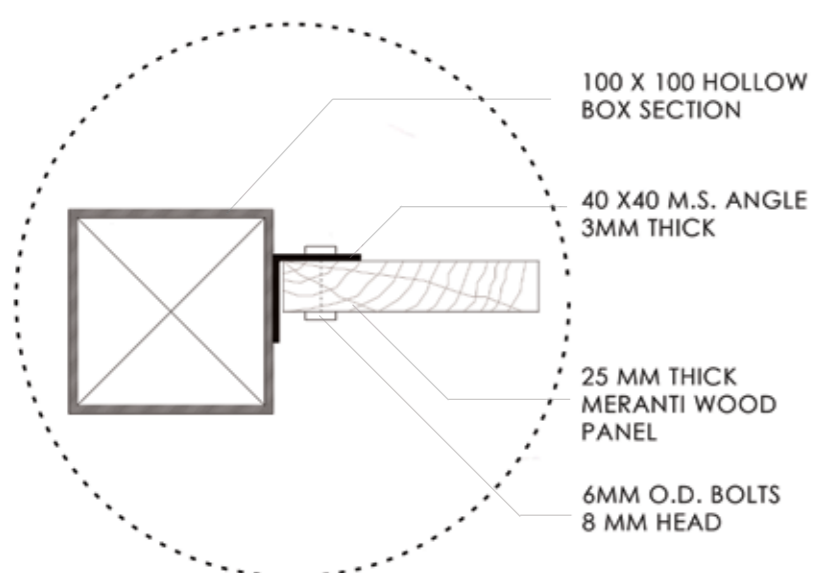
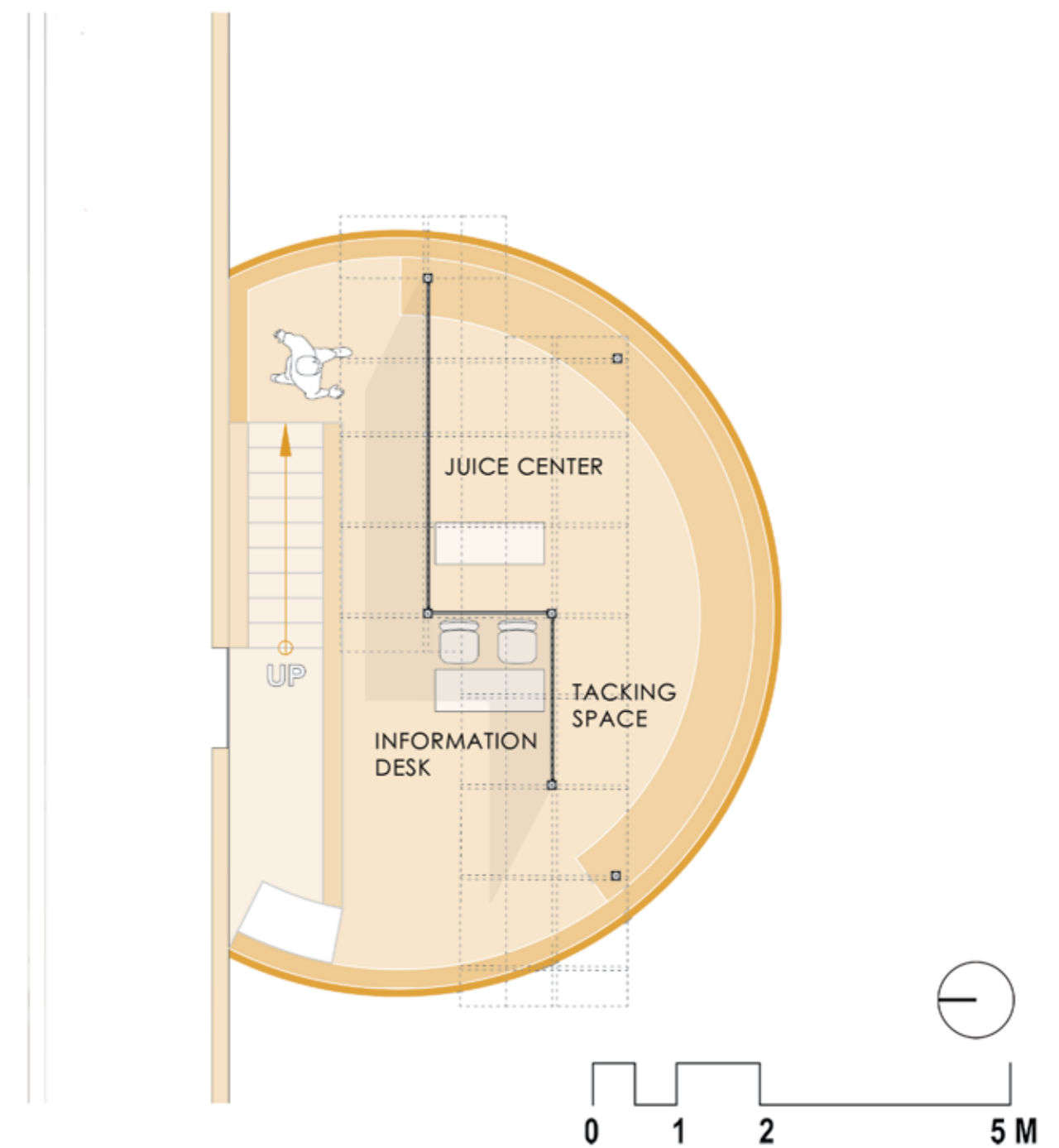
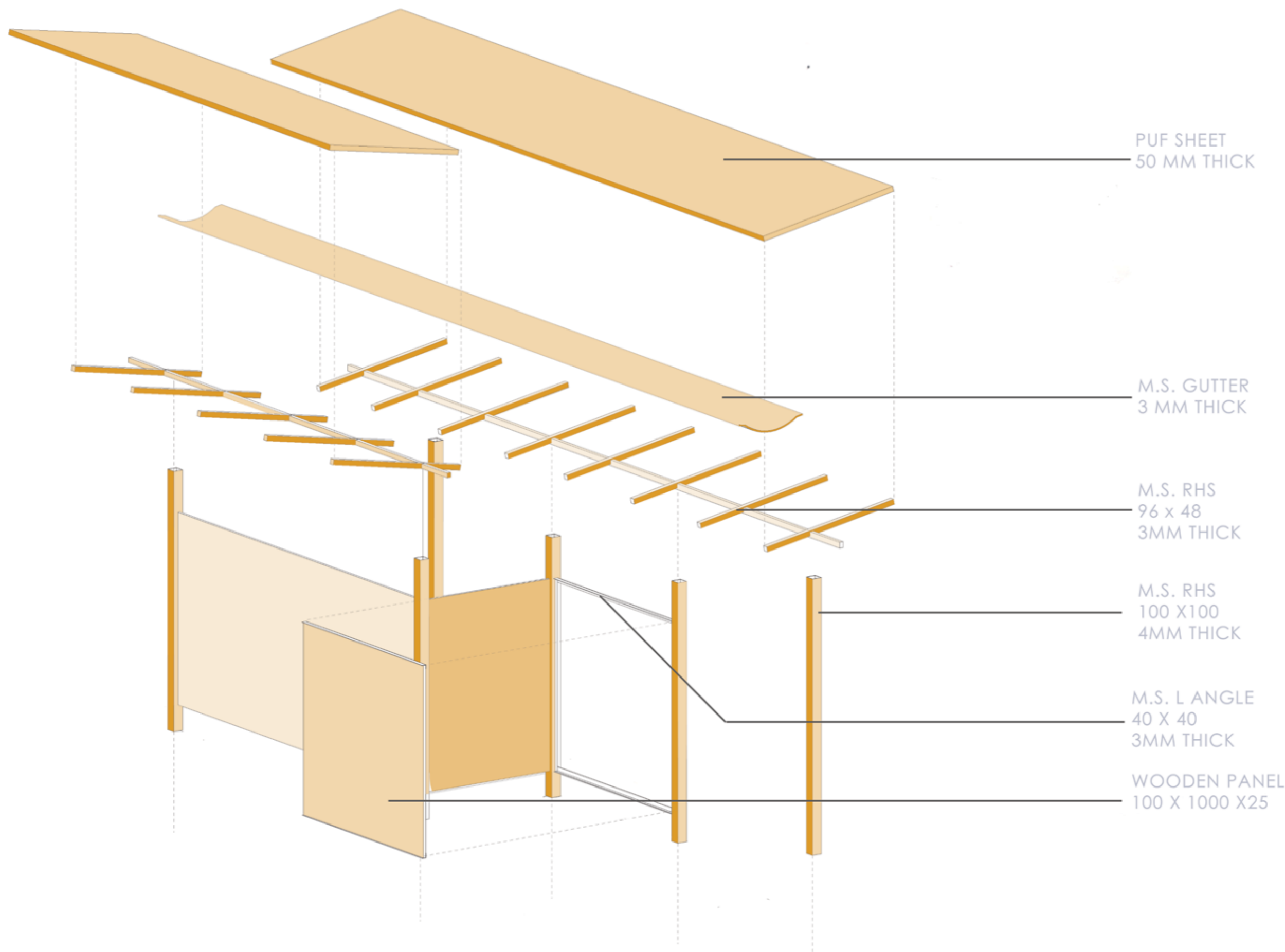

Steel column and wooden panel junction detail

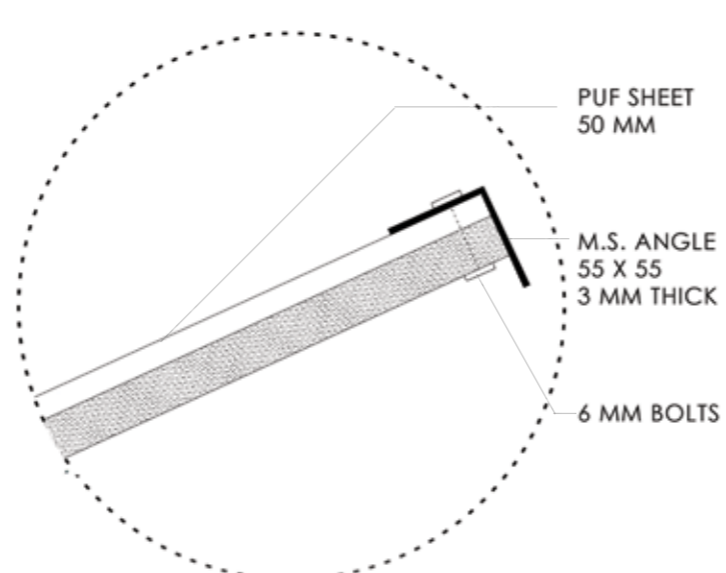

Roofing detail

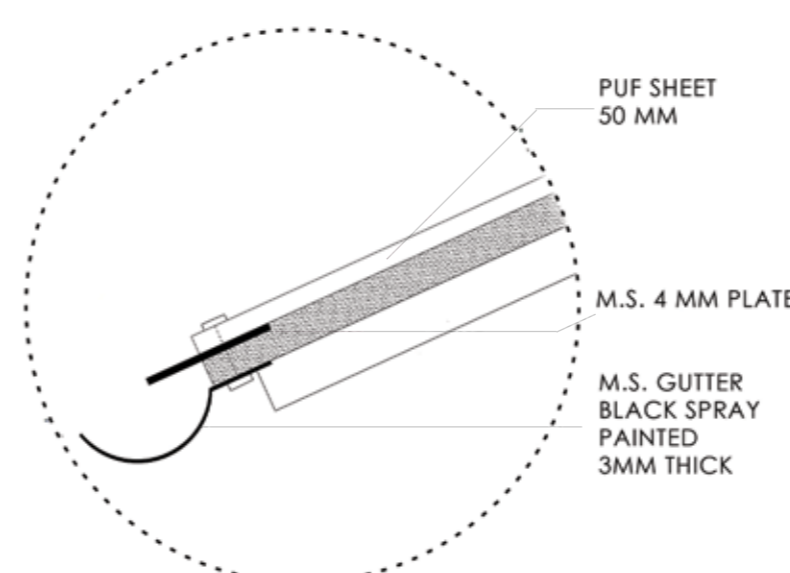

Gutter detail

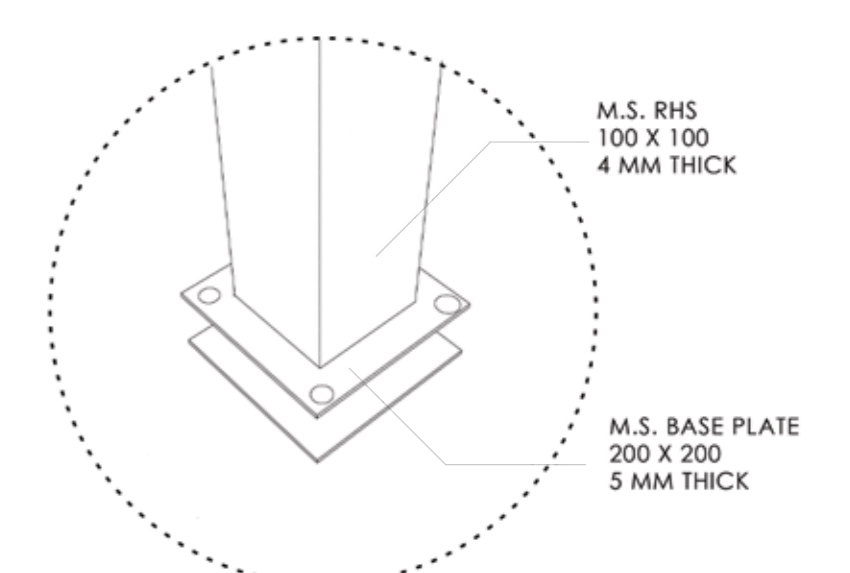

Column anchor detail

